

2-Phase Closed-loop Stepper Motor Drivers with Integrated Controller



AiC-D Series CATALOG

For your safety, read and follow the considerations written in the instruction manual, other manuals and Autonics website.

The specifications, dimensions, etc. are subject to change without notice for product improvement. Some models may be discontinued without notice.

Features

- Closed-loop system with real-time position control
- High speed & high torque drive without missing steps
- Motor driver+Controller integrated type
- Control up to 31 axes with RS-485 communication
- Windows-based software (atMotion) for easy parameter setting and monitoring
- 4 operation mode : Jog mode, Continuous mode, Index mode, Program Mode
- Built-in brake type motors available (AiC-D-B Series)

Ordering Information

This is only for reference, the actual product does not support all combinations..
For selecting the specified model, follow the Autonics website.
Select a model that matches the ordering information of the motor and the driver.

AiC - D - ① ② ③ - ④

① Frame size

Number: Frame size (Unit: mm)

③ Encoder resolution

	□ 20 / 28 / 35 mm	□ 42 / 56 / 60 mm
A	4,000 PPR (1,000 PPR × 4)	10,000 PPR (2,500 PPR × 4)
B	16,000 PPR (4,000 PPR × 4)	-

② Axial length

S: Short
M: Medium
L: Long

④ Motor type

No mark: Standard type
B: Built-in brake type

Product Components

- Product
- Instruction manual
- RS485 comm. protective connector
- Power connector
- I/O connector
- Brake connector (AiC-D-B Series)

Software

Download the installation file and the manuals from the Autonics website.

■ atMotion

The program allows to manage the motor driver's parameter setting and monitoring data.

Specifications

Model	AiC-D-20□A	AiC-D-28□B	AiC-D-35□B
Power supply	24 VDC± ±10%		
Max. RUN power ⁰¹⁾	≤ 60 W		
Stop power ⁰²⁾	≤ 10 W		
Max. RUN current ⁰³⁾	0.6 A / Phase	1.0 A / Phase	1.2 A / Phase
Stop current	20 to 100% of max. RUN current (factory default: 50%)		
Resolution	500 (factory default), 1000, 1600, 2000, 3600, 4000, 5000, 6400, 7200, 10000 PPR	500 (factory default), 1000, 1600, 2000, 3600, 5000, 6400, 7200, 10000, 16000 PPR	

Model	AiC-D-42□A-□	AiC-D-56□A-□	AiC-D-60□A-□
Power supply	24 VDC± ±10%		
Max. RUN power ⁰¹⁾	≤ 60 W	≤ 120 W	≤ 240 W
Stop power ⁰²⁾	≤ 10 W	≤ 12 W	≤ 15 W
Max. RUN current ⁰³⁾	1.7 A / Phase	3.5 A / Phase	
Stop current	20 to 100% of max. RUN current (factory default: 50%)		
Resolution	500 (factory default), 1000, 1600, 2000, 3200, 3600, 5000, 6400, 7200, 10000 PPR		

01) When changing the load rapidly, instantaneous peak current may increase. The capacity of power supply should be over 1.5 to 2 times of max. RUN power.

02) Based on ambient temp. 25°C, ambient humi. 55%RH, stop current 50%

03) RUN current varies depending on the input RUN frequency and max. RUN current at the moment varies also.

Run method	2-phase bipolar closed-loop control method
Speed filter	Disable, 2, 4, 6, 8, 10, 20, 40, 60 (factory default), 80, 100, 120, 140, 160, 180, 200 ms
Control Gain	0 (factory default) ~ 14, Fine Gain
Max. rotation speed	3000 rpm
Positioning range	-2,147,483,648 to +2,147,483,647
In-Position	Fast Response: 0 (factory default) to 7, Accurate Response: 0 to 7
Rotation direction	CW (factory default), CCW
Operation mode	Jog mode, Continuous mode, Index mode, Program mode
Home search mode	General mode, Limit mode, Zero point mode, Torque mode
Index step	64 step
Program step	256 step
Program function	Power On Program Start, Power On Home Search
Control command	ABS, INC, HOM, ICJ, IRD, OPC, OPT, JMP, REP, RPE, END, POS, TIM, CMP

I/O voltage level	[H]: 5 - 30 VDC±, [L]: 0 - 2 VDC±
Input ⁰¹⁾	Exclusive input: 20, General input: 9
Output	Standard type - Exclusive output: 4, General output: 10 Built-in brake type - Exclusive output: 6, General output: 9
External power supply	VEX (recommended: 24 VDC±); 2, GEX (GND): 2
Insulation resistance	≥ 100 MΩ (500 VDC± megger)
Dielectric strength	1,000 VAC ~ 60 Hz for 1 minute
Vibration	1.5 mm double amplitude at frequency 10 to 55 Hz (for 1 minute) in each X, Y, Z direction for 2 hours
Shock	300 m/s ² (≈ 30 G) in each X, Y, Z direction for 3 times
Ambient temp.	0 to 50°C, storage: -10 to 60°C (no freezing or condensation)
Ambient humi.	35 to 85%RH, storage: 10 to 90%RH (no freezing or condensation)
Protection rating	IP20 (IEC standard)
Approval	CE ENEC
Unit weight (packaged)	≈ 300 g (≈ 460 g)

01) Brake ON/OFF function can be changed from general input IN8 in case of built-in brake type.

Dimensions

• Unit: mm, For the detailed drawings, follow the Autonics website.

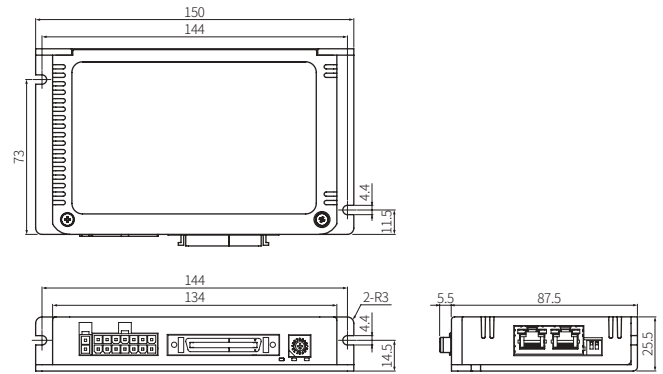

Unit Descriptions

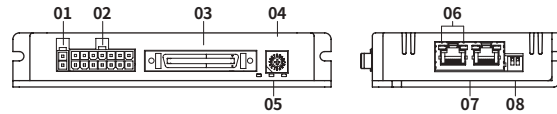

01. Power connector

02. Motor + Encoder connector

03. I/O connector

04. Comm. ID setting rotary switch

05. Status indicator

06. RS485 comm. indicator

07. RS485 comm. connector

08. Comm. ID setting / Terminating resistance DIP switch

Communication Interface

■ RS485

Comm. protocol	Modbus RTU
Applied standard	Compliance with EIA RS485
Max. connections	31 units (address: 01 to 31)
Synchronous method	Asynchronous
Comm. method	2-wire half duplex
Comm. distance	≤ 800 m
Baud rate	9600, 19200, 38400, 57600, 115200 (factory default) bps
Start bit	1 bit (fixed)
Data bit	8 bit (fixed)
Parity bit	None (factory default), Even, Odd
Stop bit	1 bit (factory default), 2 bit

Sold Separately

- Power cable: CJ-PW-□
- Motor + Encoder cable: C1D14M-□ (fixed type), C1DF14M-□ (flexible type)
- I/O Cable: CO50-MP□-R (specifications: AiC TAG)

Sold Separately : Power Cable

■ CJ-PW-□

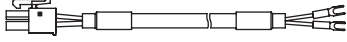

- Recommended to use ferrite core at both ends of the cable.
- The model name is 010, 020 which indicates the cable length.
E.g.) CJ-PW-010: 1 m power cable

Sold Separately : Motor + Encoder Cable

■ Fixed type: C1D14M-□, Flexible type: C1DF14M-□



- Recommended to use ferrite core at both ends of the cable.
- The model name is 1, 2, 3, 5, 7, 10, 15, 20 which indicates the cable length.
E.g.) C1DF14M-10: 10 m flexible type, Motor + Encoder cable

Sold Separately : I/O Cable

■ CO50-MP□-R (specifications: AiC TAG)

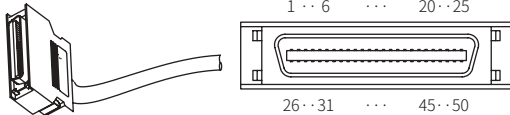

Pin	Function (Name TAG)	Cable Color	Dot line color-number	Pin	Function (Name TAG)	Cable Color	Dot line color-number
1	N·C, Brake+	Orange	Black-1	26	IN0	White	Red-3
2	N·C, Brake-		Red-1	27	IN1		Black-4
3	Reset		Black-2	28	IN2		Red-4
4	Start		Red-2	29	N·C		Black-5
5	Stop		Black-3	30	IN3		Red-5
6	EMG		Red-3	31	IN4		Black-1
7	Step0/+Run/+Jog	Yellow	Black-4	32	IN5	Gray	Red-1
8	Step1/-Run/-Jog		Red-4	33	IN6		Black-2
9	Step2/SSP0		Black-5	34	IN7		Red-2
10	Step3/SSP1		Red-5	35	IN8, Brake ON/OFF		Black-3
11	Step4/MSP0		Black-1	36	VEX		Red-3
12	Step5/MSP1		Red-1	37	GEX		Black-4
13	MD0/HMD0		Black-2	38	Alarm		Red-4
14	MD1/HMD1		Red-2	39	Compare1 (Trigger)		Black-5
15	Pause		Black-3	40	Compare2 (Trigger)		Red-5
16	Servo ON/OFF	Red-3	41	OUT0	Pink	Black-1	
17	Home	Black-4	42	OUT1		Red-1	
18	Alarm Reset	Red-4	43	OUT2		Black-2	
19	+Limit	Black-5	44	OUT3		Red-2	
20	-Limit	Red-5	45	OUT4		Black-3	
21	ORG	Black-1	46	OUT5		Red-3	
22	SD	Red-1	47	OUT6		Black-4	
23	In-Position	Black-2	48	OUT7		Red-4	
24	VEX	Red-2	49	OUT8		Black-5	
25	GEX	Black-3	50	OUT9, N·C		Red-5	

- Recommended to use ferrite core at both ends of the cable.
- The model name is 010, 020, 030, 050, 070, 100, 150, 200 which indicates the cable length.
E.g.) CO50-MP070-R: 7 m I/O cable